



US009203051B2

(12) **United States Patent**  
**Byun et al.**

(10) **Patent No.:** **US 9,203,051 B2**  
(45) **Date of Patent:** **Dec. 1, 2015**

(54) **ORGANIC LIGHT EMITTING DISPLAY APPARATUS INCLUDING VISCOELASTIC LAYER AND METHOD FOR MANUFACTURING THE SAME**

USPC ..... 257/40, 79, 100, E39.007; 438/28  
See application file for complete search history.

(71) Applicant: **LG Display Co., Ltd.**, Seoul (KR)  
(72) Inventors: **Hyun Tae Byun**, Incheon (KR); **Eun Ah Song**, Paju-si (KR); **Hee Chul Lim**, Paju-si (KR)

(56) **References Cited**

U.S. PATENT DOCUMENTS

5,296,974 A *	3/1994	Tada	.....	G02F 1/172
				359/228
2004/0041147 A1 *	3/2004	Park	.....	H01L 51/5256
				257/40
2011/0057208 A1 *	3/2011	Jeon	.....	H01L 51/5246
				257/88
2013/0100529 A1	4/2013	Kitagawa et al.		
2014/0308494 A1	10/2014	Iwaya et al.		

(73) Assignee: **LG DISPLAY CO., LTD.**, Seoul (KR)  
(\* ) Notice: Subject to any disclaimer, the term of this patent is extended or adjusted under 35 U.S.C. 154(b) by 0 days.

FOREIGN PATENT DOCUMENTS

JP	2003-086352 A	3/2003
JP	2004-095551 A	3/2004
JP	2007-200692 A	8/2007
JP	2010-003635 A	1/2010

(21) Appl. No.: **14/535,471**  
(22) Filed: **Nov. 7, 2014**

(Continued)

(65) **Prior Publication Data**  
US 2015/0144909 A1 May 28, 2015

*Primary Examiner* — Duy T Nguyen  
(74) *Attorney, Agent, or Firm* — Dentons US LLP

(30) **Foreign Application Priority Data**  
Nov. 27, 2013 (KR) ..... 10-2013-0145331

(57) **ABSTRACT**

(51) **Int. Cl.**  
*H01L 51/00* (2006.01)  
*H01L 51/52* (2006.01)  
*H01L 27/32* (2006.01)  
(52) **U.S. Cl.**  
CPC ..... *H01L 51/5253* (2013.01); *H01L 27/323* (2013.01); *H01L 51/5256* (2013.01); *H01L 51/5262* (2013.01); *H01L 51/5281* (2013.01); *H01L 2251/5338* (2013.01)

Disclosed is an organic light emitting display (OLED) apparatus that includes a substrate; an organic light emitting element on the substrate, the organic light emitting element including a first electrode, an organic light emitting layer and a second electrode; a viscoelastic layer on the organic light emitting element, wherein an elastic portion of the viscoelastic layer is about 30% or more, the elastic portion being defined by <Equation 1>: Elastic portion ( $E_p$ ) (%) =  $(\sigma/\sigma_0) \times 100$ , wherein  $\sigma_0$  is an initial stress generated when a strain of about 50% is applied to the viscoelastic layer and  $\sigma$  is a final stress measured after the strain is continuously applied thereto for about 180 seconds, with the initial stress  $\sigma_0$  and the final stress  $\sigma$  being measured at about 80° C. through a relaxation modulus test.

(58) **Field of Classification Search**  
CPC . H01L 51/50; H01L 51/56; H01L 2251/5338; H01L 51/5253; H01L 27/323; H01L 51/5256; H01L 51/5262; H01L 51/5281

**10 Claims, 10 Drawing Sheets**

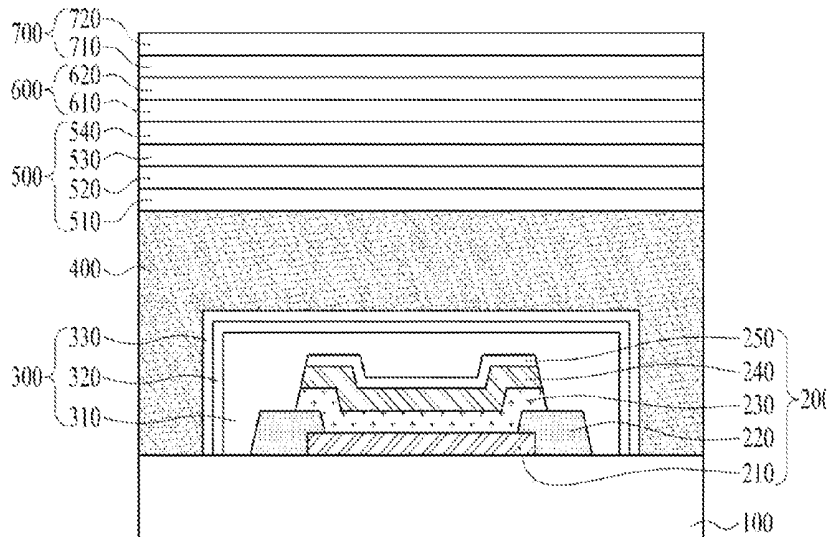

(56) **References Cited**

FOREIGN PATENT DOCUMENTS

JP 2010-133987 A 6/2010

JP 2012-133312 A 7/2012  
JP 2013-077460 A 4/2013  
KR 10-2009-0128301 A 12/2009  
WO 2013-065812 A1 5/2013

\* cited by examiner

FIG. 1  
(Related Art)

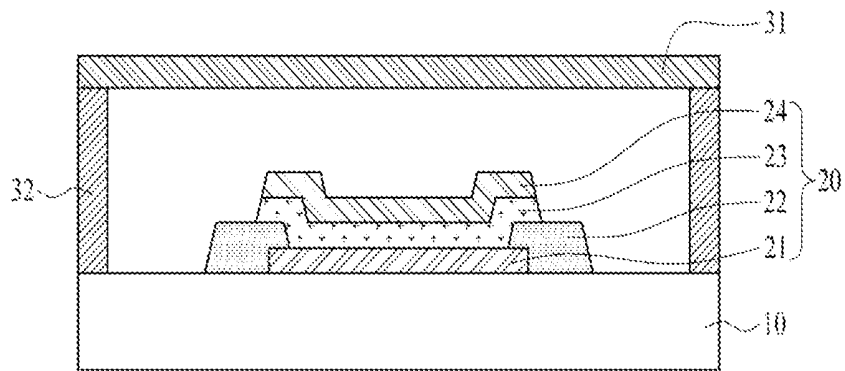

FIG. 2  
(Related Art)

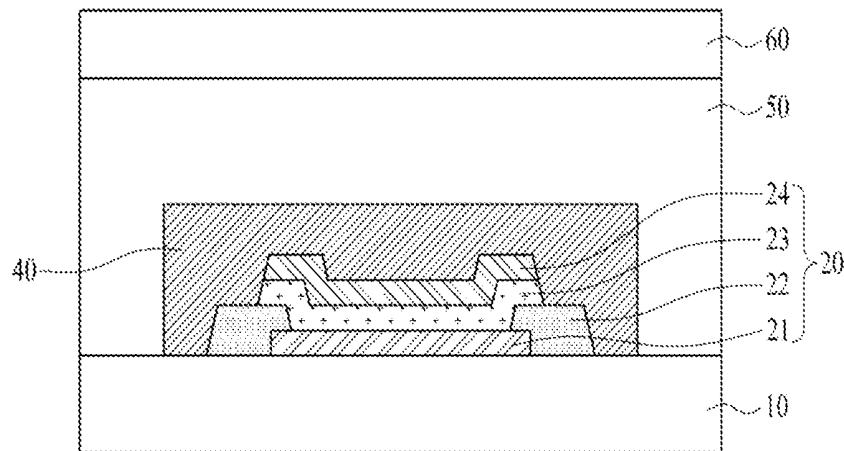

FIG. 3  
(Related Art)

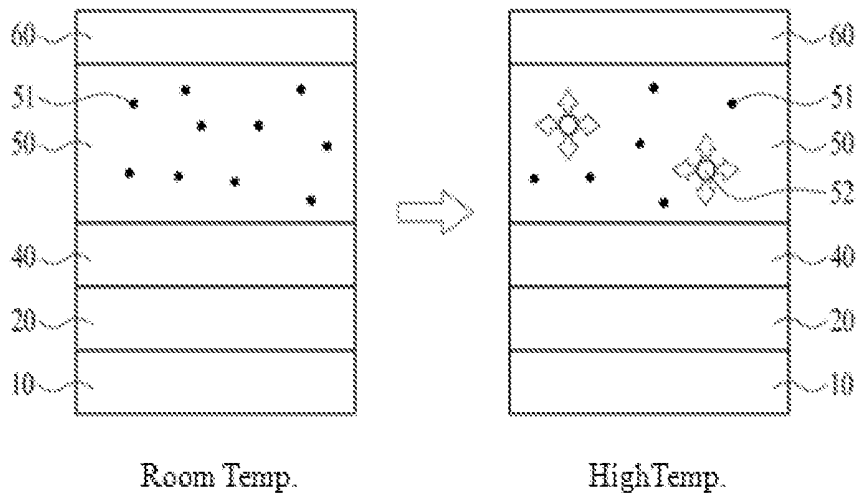

FIG. 4

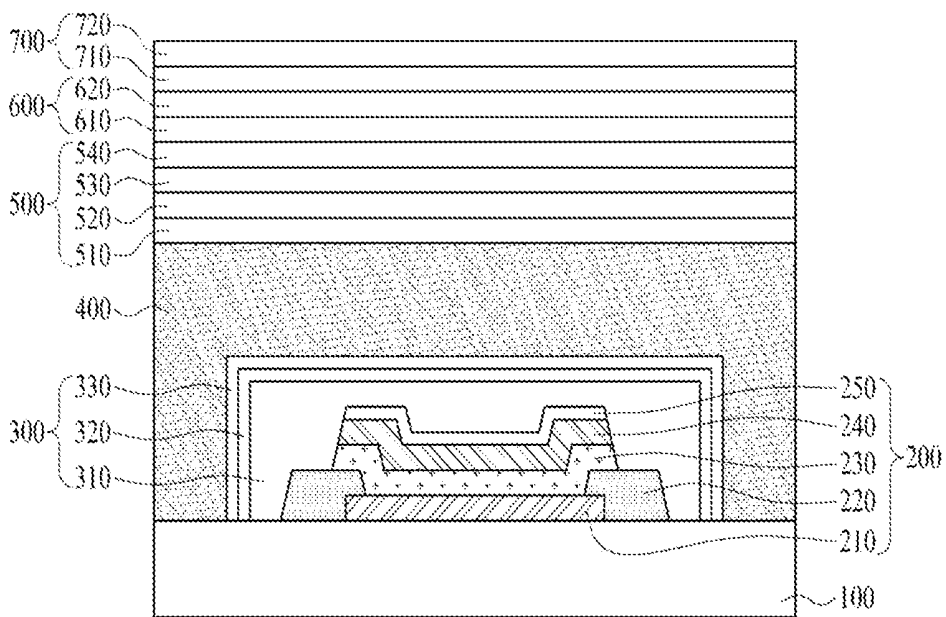

FIG. 5

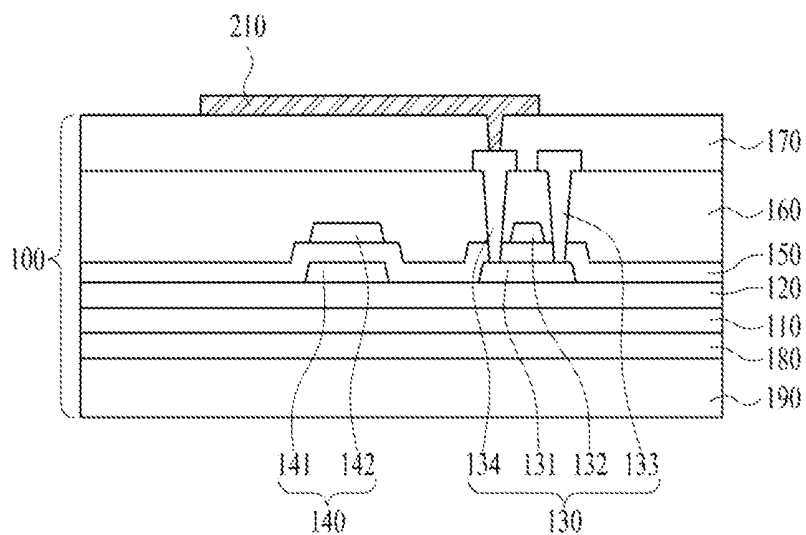

FIG. 6

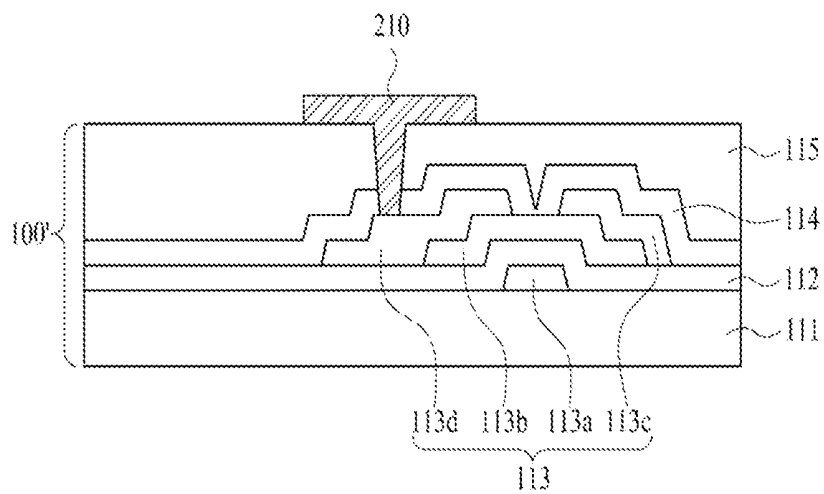

FIG. 7

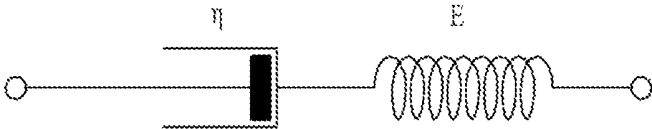

FIG. 8

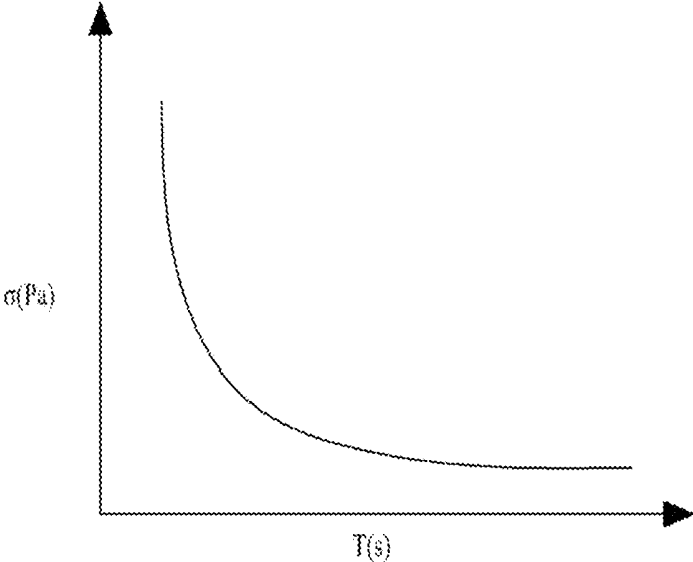

FIG. 9

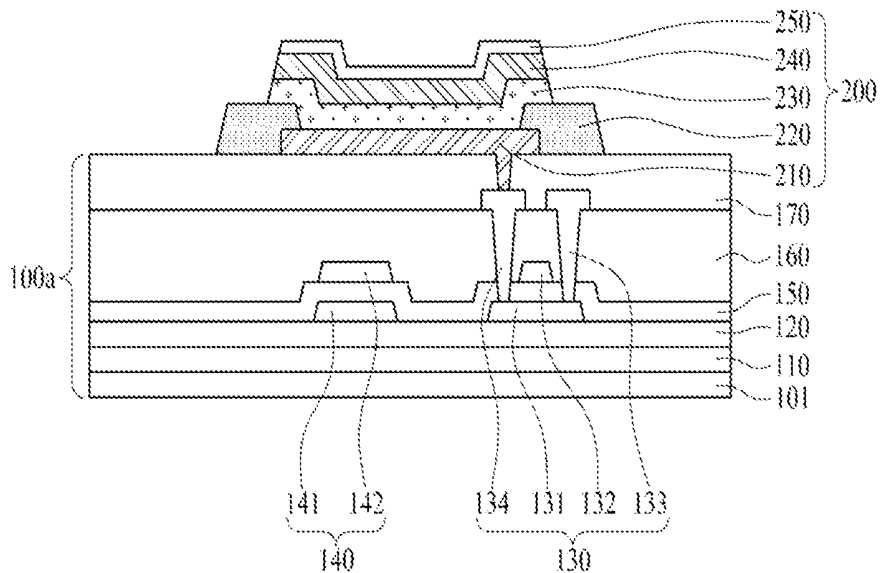

FIG. 10

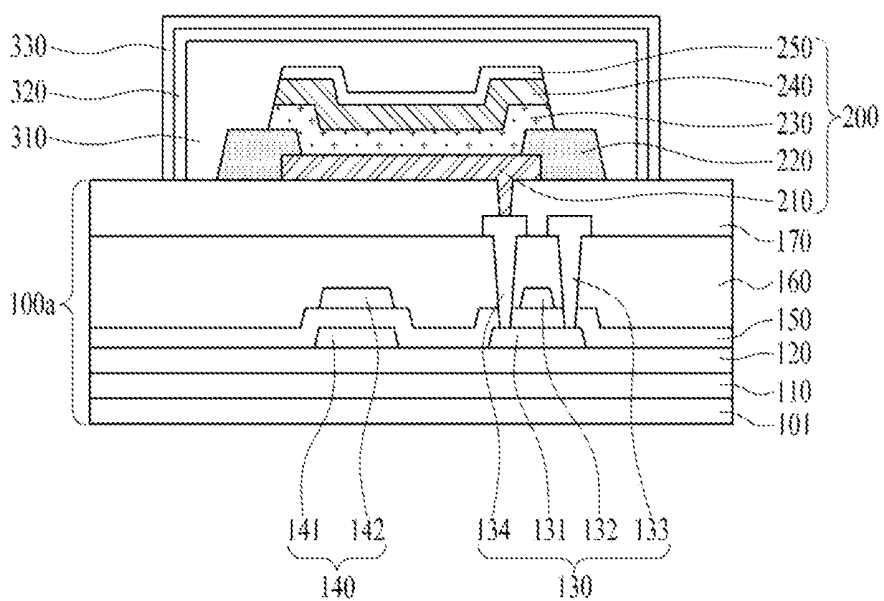

FIG. 11

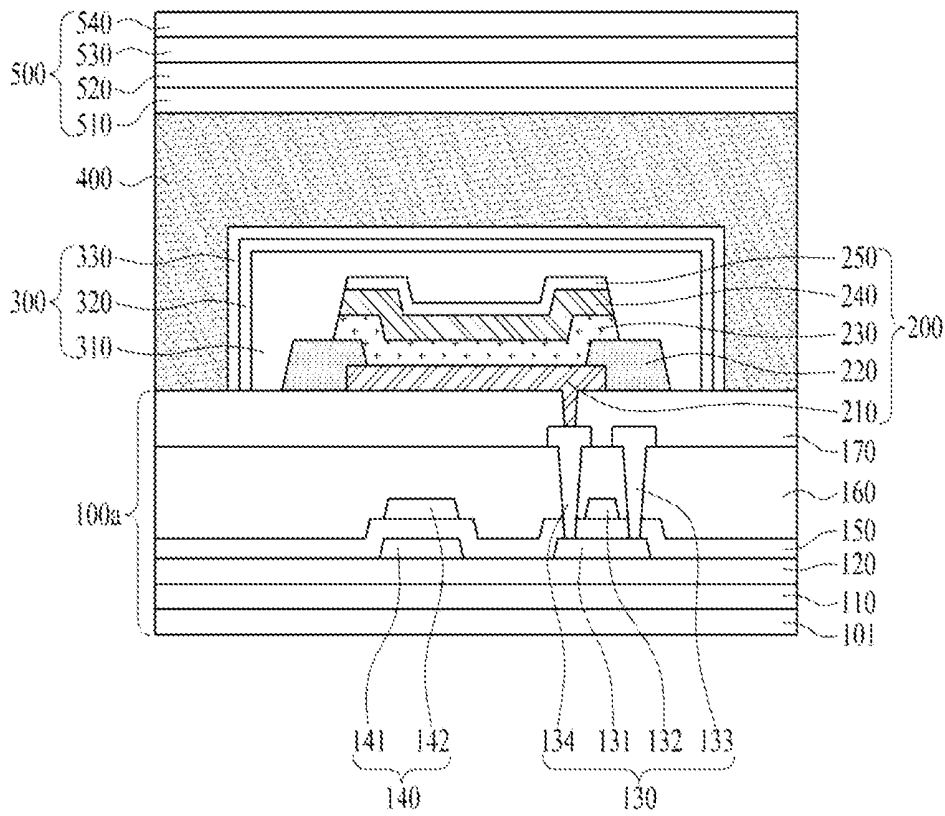

FIG. 12

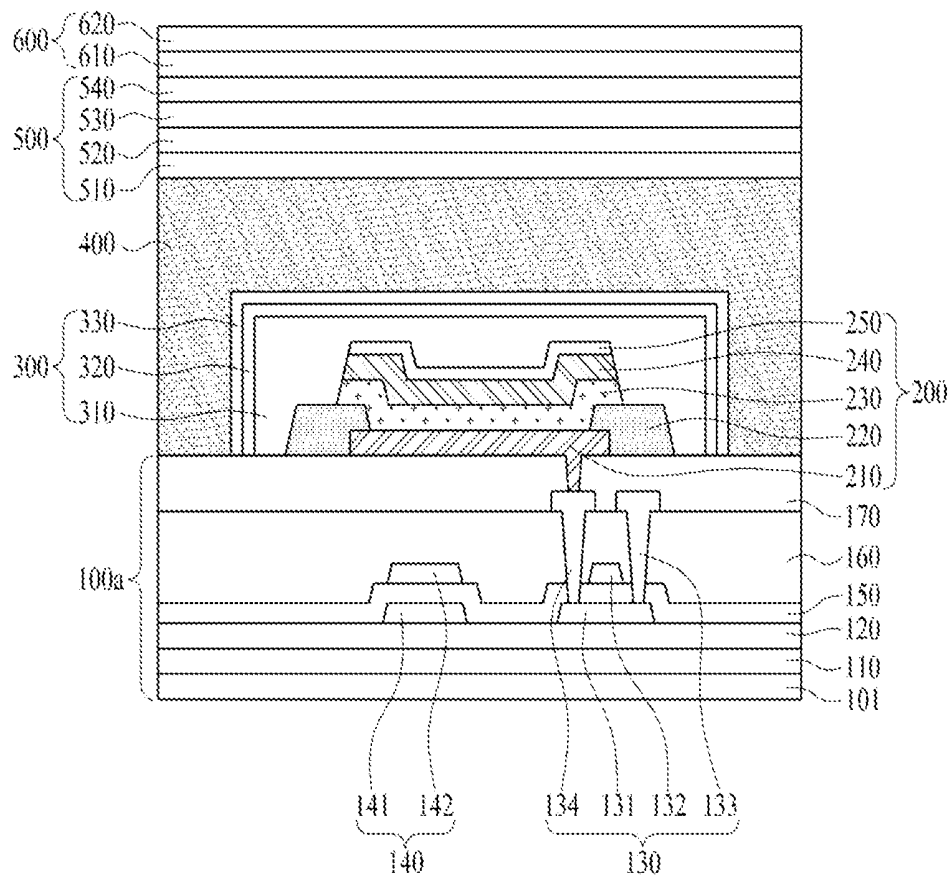

FIG. 13

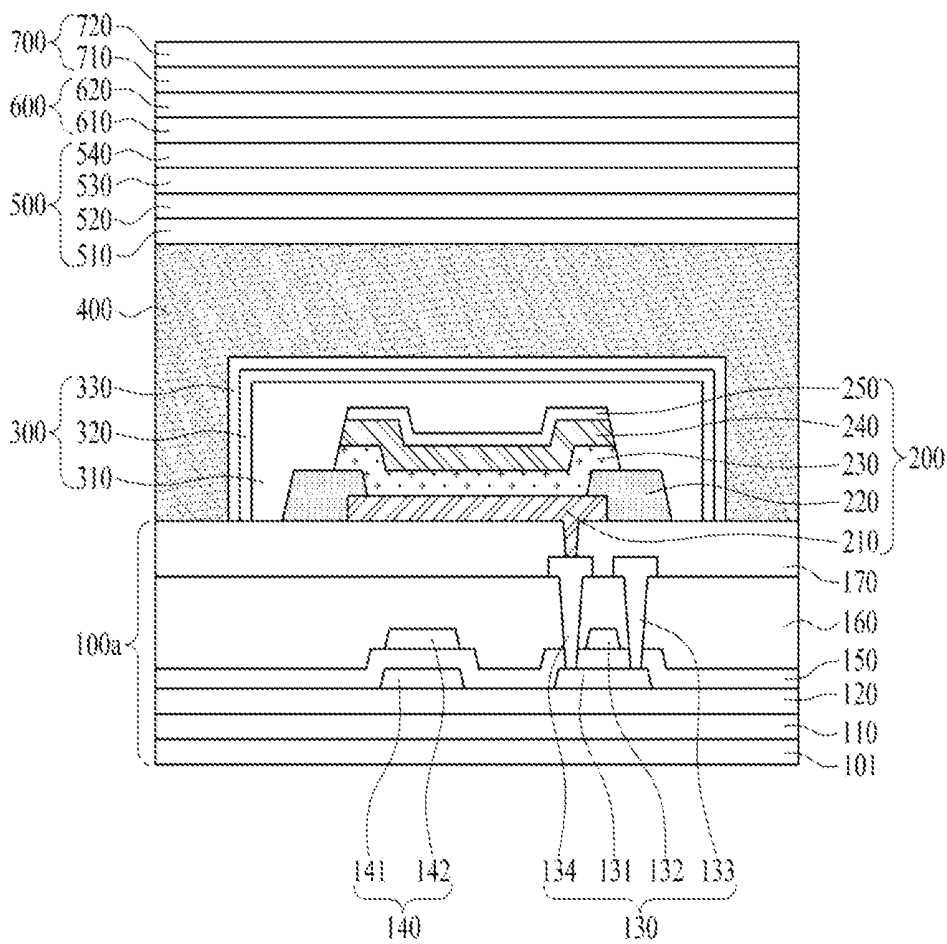

FIG. 14

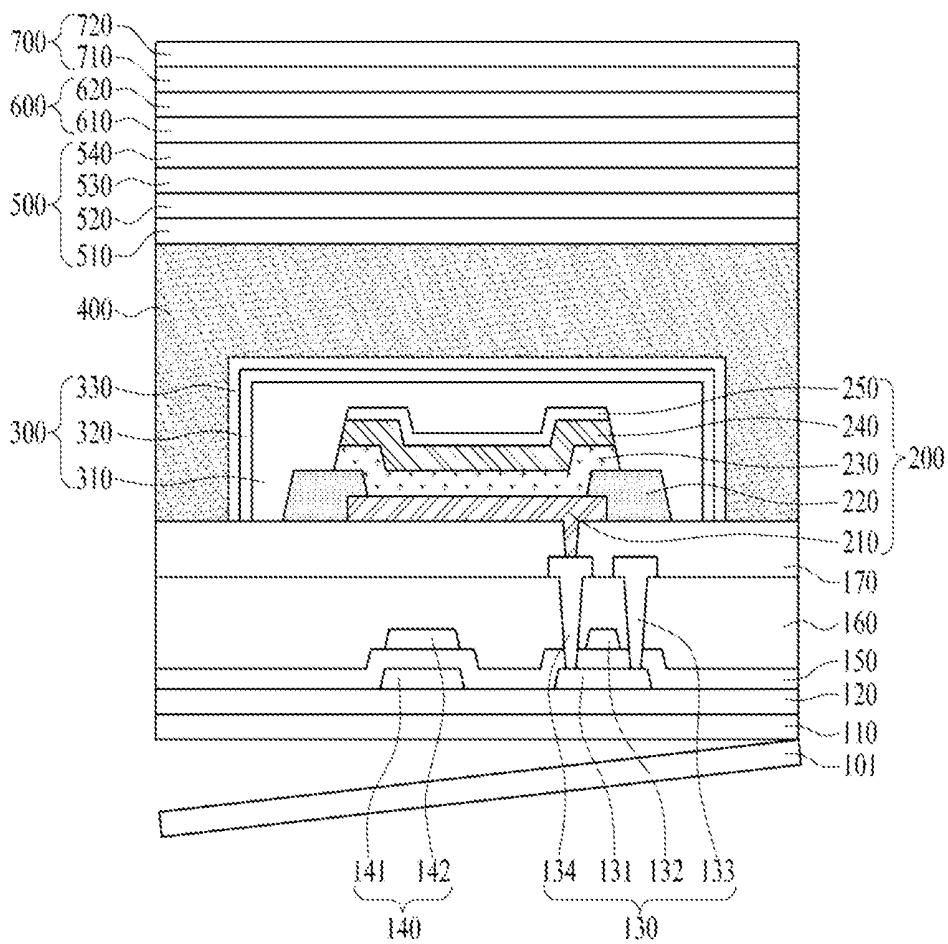
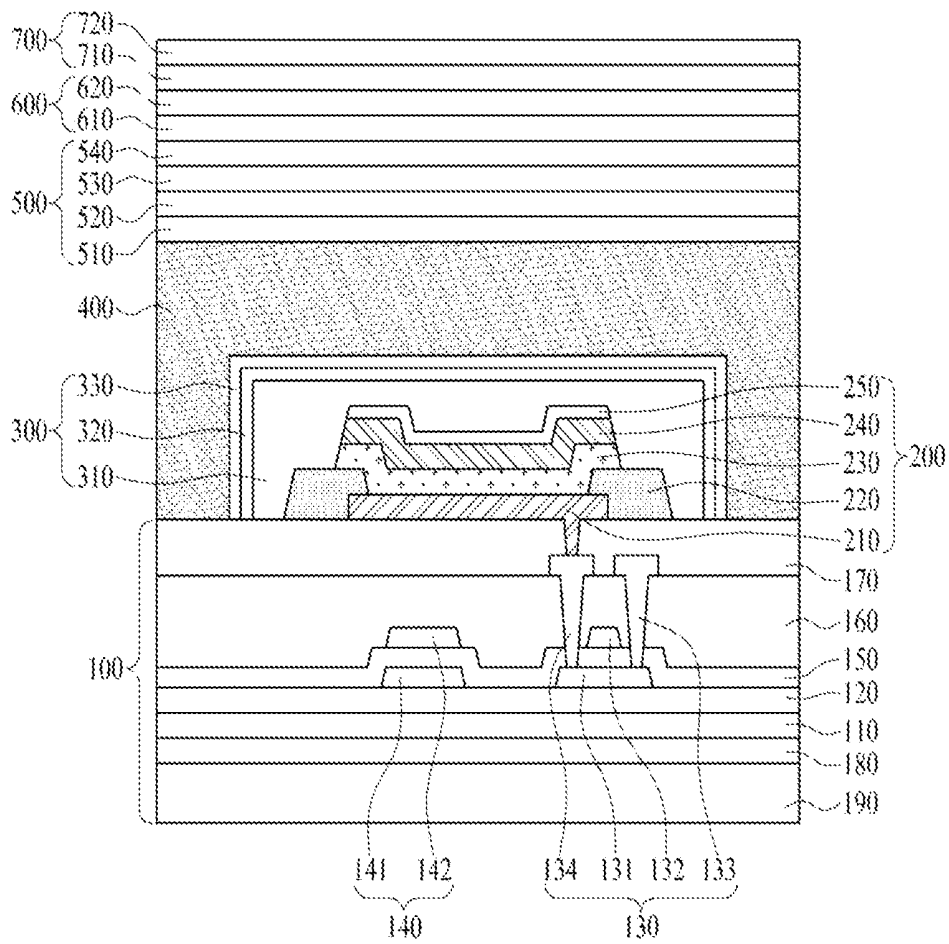

FIG. 15



**ORGANIC LIGHT EMITTING DISPLAY  
APPARATUS INCLUDING VISCOELASTIC  
LAYER AND METHOD FOR  
MANUFACTURING THE SAME**

CROSS REFERENCE TO RELATED  
APPLICATIONS

This application claims the benefit of Korean Patent Application No. 10-2013-0145331 filed on Nov. 27, 2013, which is hereby incorporated by reference for all purposes as if fully set forth herein.

BACKGROUND OF THE INVENTION

1. Field of the Invention

The present disclosure relates to an organic light emitting display apparatus and method for manufacturing the same, and more particularly, to an organic light emitting display apparatus and method for manufacturing the same that is capable of reducing visually recognizable bubbles in the encapsulation structure.

2. Discussion of the Related Art

Currently, a liquid crystal display (LCD) apparatus is used most widely among various flat panel display apparatuses. Since the LCD apparatus is a non-emissive apparatus that does not generate light by itself, the LCD apparatus is relatively vulnerable in view of brightness, contrast ratio and viewing angle.

As a flat panel display apparatus that may solve such drawbacks of the LCD apparatus, an organic light emitting display (OLED) apparatus has received attention. Since the OLED apparatus is an emissive apparatus that generates light by itself, the OLED apparatus has brightness, contrast ratio and viewing angle that are better than those of the non-emissive apparatus. Also, since the OLED apparatus does not require a separate backlight, the OLED apparatus may be more lightweight and thinner than the LCD apparatus, and may consume less power than the LCD apparatus.

The OLED apparatus typically includes a thin film transistor, a first electrode electrically connected with the thin film transistor, a light-emissive organic layer on the first electrode, and a second electrode on the light-emissive organic layer.

Since the light-emissive organic layer is vulnerable to water and oxygen, an encapsulation structure is typically provided to prevent a light-emissive defect caused by permeation of water and oxygen into the light-emissive organic layer.

FIGS. 1 and 2 briefly illustrate cross-sectional views of OLED apparatuses having different encapsulation structures (hereinafter, referred to as "first and second type encapsulation structures").

As illustrated in FIGS. 1 and 2, these OLED apparatuses are substantially identical to each other in that they include a TFT substrate 10, which includes a thin film transistor (not shown), and an organic light emitting element 20 on the TFT substrate 10. The organic light emitting element 20 includes a first electrode 21 on the TFT substrate 10, which is electrically connected with the thin film transistor, a bank layer 22 formed on the TFT substrate 10 on which the first electrode 21 is formed and having a bank hole for exposing at least a part of the first electrode 21 corresponding to a light emitting area, a light-emissive organic layer 23 on the part of the first electrode 21, which is exposed through the bank hole of the bank layer 22, and a second electrode 24 on the light-emissive organic layer 23.

However, as illustrated in FIG. 1, the first type encapsulation structure includes an encapsulation glass 31 spaced apart from the organic light emitting element 20 at a predetermined distance, and a frit layer 32 disposed between the TFT substrate 10 and the encapsulation glass 31 at corners of the OLED apparatus.

In the first type encapsulation structure, the encapsulation glass 31 mainly prevents oxygen/water from being permeated into the light-emissive organic layer 23 through a face of the OLED apparatus, and the frit layer 32 mainly prevents oxygen/water from being permeated into the light-emissive organic layer 23 through a side of the organic light emitting display apparatus.

However, the OLED apparatus having the first type encapsulation structure has a problem in that the OLED apparatus is vulnerable to external impact, and thus may not be suitable for a flexible display apparatus.

In order to address such a problem of the first type encapsulation structure, the second type encapsulation structure has been suggested.

According to the second type encapsulation structure, as illustrated in FIG. 2, a passivation layer 40 is formed on the TFT substrate 10, in which the organic light emitting element 20 is formed, to fully cover the organic light emitting device 20. Subsequently, an encapsulation film 60 is bonded onto the TFT substrate 10, on which the passivation layer 40 is formed, using an adhesive layer 50.

In the second type encapsulation structure, the encapsulation film 60, the adhesive layer 50 and the passivation layer 40 mainly prevent oxygen/water from being permeated into the light-emissive organic layer 23 through the face of the organic light emitting display apparatus, and the adhesive layer 50 and the passivation layer 40 mainly prevent oxygen/water from being permeated into the light-emissive organic layer 23 through the side of the organic light emitting display apparatus.

However, the conventional adhesive layer 50 applied to the second type encapsulation structure has relatively low heat-resistance. Due to such low heat-resistance and difference in coefficient of thermal expansion with an adjacent structure, the adhesive layer 50 may be thermally deformed under an environment of high temperature and high humidity, as illustrated in FIG. 3. This may lead to a problem in that fine bubbles 51 inside the adhesive layer 50 are combined with one another to generate bubble(s) 52 that may be recognized visually.

These bubbles may be regarded as a product defect, and thus the productivity of the OLED apparatus may be lowered. The occurrence of these bubbles after the product has been sold may lower reliability and damage the brand image.

SUMMARY OF THE INVENTION

Accordingly, the present invention is directed to an organic light emitting display apparatus and method for manufacturing the same, which substantially obviates one or more problems due to limitations and disadvantages of the related art.

An advantage of the present invention is to provide an organic light emitting display apparatus and method for manufacturing the same that is capable of reducing visually recognizable bubbles that otherwise might be generated under an environment of high temperature and high humidity within the encapsulation structure.

Additional features and advantages of the invention will be set forth in the description which follows, and in part will be apparent from the description, or may be learned by practice of the invention. These and other advantages of the invention

will be realized and attained by the structure particularly pointed out in the written description and claims hereof as well as the appended drawings.

To achieve these and other advantages and in accordance with the purpose of the present invention, as embodied and broadly described, an organic light emitting display (OLED) apparatus may, for example, include a substrate; an organic light emitting element on the substrate, the organic light emitting element including a first electrode, an organic light emitting layer and a second electrode; a viscoelastic layer on the organic light emitting element, wherein an elastic portion of the viscoelastic layer is about 30% or more, the elastic portion being defined by  $\text{Elastic portion } (E_p) (\%) = (\sigma / \sigma_0) \times 100$ , wherein  $\sigma_0$  is an initial stress generated when a strain of about 50% is applied to the viscoelastic layer and  $\sigma$  is a final stress measured after the strain is continuously applied thereto for about 180 seconds, with the initial stress  $\sigma_0$  and the final stress  $\sigma$  being measured at about 80° C. through a relaxation modulus test.

In another aspect of the present invention, a method of manufacturing an organic light emitting display (OLED) apparatus may, for example, include forming an organic light emitting element on a first substrate, which includes forming a first electrode, forming an organic light emitting layer and forming a second electrode; forming a viscoelastic layer on the organic light emitting element, wherein an elastic portion of the viscoelastic layer is about 30% or more, with the elastic portion being defined by  $\text{Elastic portion } (E_p) (\%) = (\sigma / \sigma_0) \times 100$ , wherein  $\sigma_0$  is an initial stress generated when a strain of about 50% is applied to the viscoelastic layer and  $\sigma$  is a final stress measured after the strain is continuously applied thereto for about 180 seconds, with the initial stress  $\sigma_0$  and the final stress  $\sigma$  being measured at about 80° C. through a relaxation modulus test.

It is to be understood that both the foregoing general description and the following detailed description are exemplary and explanatory and are intended to provide further explanation of the invention as claimed.

#### BRIEF DESCRIPTION OF THE DRAWINGS

The accompanying drawings, which are included to provide a further understanding of the invention and are incorporated in and constitute a part of this application, illustrate embodiment(s) of the invention and together with the description serve to explain the principles of the invention. In the drawings:

FIG. 1 briefly illustrates a cross-section of an organic light emitting display apparatus having a first encapsulation structure;

FIG. 2 briefly illustrates a cross-section of an organic light emitting display apparatus having a second encapsulation structure;

FIG. 3 is a cross-sectional view briefly illustrating generation of bubbles in an encapsulation structure of an organic light emitting display apparatus under an environment of high temperature and high humidity;

FIG. 4 is a cross-sectional view briefly illustrating an organic light emitting display apparatus according to an embodiment of the present invention;

FIG. 5 is a cross-sectional view briefly illustrating a TFT substrate according to an embodiment of the present invention;

FIG. 6 is a cross-sectional view briefly illustrating a TFT substrate according to another embodiment of the present invention;

FIG. 7 is a Maxwell model of a viscoelastic material;

FIG. 8 is a graph illustrating variation of stress with time of a viscoelastic material measured through a relaxation modulus test; and

FIGS. 9 to 15 are cross-sectional views illustrating a method for manufacturing an organic light emitting display apparatus according to an embodiment of the present invention.

#### DETAILED DESCRIPTION OF THE INVENTION

Reference will now be made in detail to embodiments of the present invention, examples of which are illustrated in the accompanying drawings. Wherever possible, the same reference numbers may be used throughout the drawings to refer to the same or like parts.

When a structure is formed "on" another structure, it is to be understood that these structures are in contact with each other or that a third structure(s) is interposed between the structures. However, if the terminology "directly on" is used, it is to be understood that these structures are in contact with each other.

FIG. 4 briefly illustrates a cross-section of an organic light emitting display (OLED) apparatus according to an embodiment of the present invention.

The OLED apparatus includes a TFT substrate 100, which includes a thin film transistor, an organic light emitting element 200, a passivation layer 300 formed on the organic light emitting element 200, a viscoelastic layer 400 formed on the passivation layer 300 to cover the passivation layer 300, and an encapsulation film 500 on the viscoelastic layer 400.

As illustrated in FIG. 4, the OLED apparatus may further include a circular polarizing plate 600 on the encapsulation film 500, and a front module 700 on the circular polarizing plate 600.

FIG. 5 briefly illustrates a cross-section of a TFT substrate 100 according to an embodiment of the present invention.

As illustrated in FIG. 5, the TFT substrate 100 includes a polyimide film 110, a buffer layer 120 on one surface of the polyimide film 110, a thin film transistor 130 and a capacitor 140 formed on the buffer layer 120, and a rear plate 190 attached onto another surface of the polyimide film 110 using an adhesive layer 180.

The thin film transistor 130 includes a semiconductor layer 131, a gate electrode 132, and source and drain electrodes 133 and 134. The capacitor 140 includes a capacitor lower electrode 141 and a capacitor upper electrode 142.

A gate insulating film 150 is formed between the semiconductor layer 131 and the gate electrode 132 and between the capacitor lower electrode 141 and the capacitor upper electrode 142. An interlayer insulating film 160 is formed on the capacitor upper electrode 142 and between the gate electrode 132 and the source and drain electrodes 133 and 134.

An overcoat layer 170 is formed on the interlayer insulating film 160 and the source and drain electrodes 133 and 134 in order to passivate the thin film transistor 130 and the capacitor 140 and planarize a step difference caused by the thin film transistor 130.

A first electrode 210 of the organic light emitting element 200 is electrically connected with the drain electrode 134 of the thin film transistor 130 through a hole formed in the overcoat layer 170.

Although the TFT substrate 100 illustrated in FIG. 5 has a structure for a flexible display apparatus and includes a top-gate type thin film transistor where the gate electrode 132 is disposed above the semiconductor layer 131, the present invention is not limited to such a structure of FIG. 5, and the

TFT substrate **100** may include a bottom-gate type thin film transistor where the gate electrode is located below the semiconductor layer or have a non-flexible structure.

For example, as illustrated in FIG. 6, the TFT substrate **100'** includes a substrate **111** formed of glass or plastic material, a gate electrode **113a** on the substrate **111**, a gate insulating film **112** and the gate electrode **113a**, a semiconductor layer **113b** overlapped with the gate electrode **113a**, with the gate insulating film **112** interposed between the semiconductor **113b** and the gate electrode **113a**, source and drain electrodes **113c** and **113d** spaced apart from each other on the gate insulating film **112** and the semiconductor layer **113b**, and an inorganic insulating film **114** and an organic insulating film **115** sequentially formed on the substrate **111** provided with the thin film transistor **113**. The first electrode **210** of the organic light emitting element **200** is electrically connected with the drain electrode **113d** of the thin film transistor **113** through a hole formed in the inorganic insulating film **114** and the organic insulating film **115**.

Hereinafter, the organic light emitting element **200** on the TFT substrate **100** according to an embodiment of the present invention will be described in more detail with reference to FIG. 4.

The organic light emitting element **200** includes a first electrode **210** on the TFT substrate **100**, a bank layer **220** formed on the first electrode **210** and having a bank hole to expose at least a part of the first electrode **210** corresponding to a light emitting area, a light-emissive organic layer **230** on the part of the first electrode **210**, which is exposed through the bank hole of the bank layer **220**, a second electrode **240** on the light-emissive organic layer **230**, and a capping layer **250** on the second electrode **240**.

The first electrode **210** is electrically connected with the thin film transistor of the TFT substrate **100** (more specifically, electrically connected with the drain electrode **134**). The first electrode **210** may be an anode electrode and formed of a transparent conductive material having a high work function, such as indium tin oxide (ITO), indium zinc oxide (IZO), indium tin zinc oxide (ITZO), indium cerium oxide (ICO), or ZnO.

The bank hole of the bank layer **220** may define the light emitting area by exposing at least a part of the first electrode **210**.

The light-emissive organic layer **230** formed on the first electrode **210** and a part of the bank layer **220** may include a light emitting layer, a hole injection layer and/or a hole transport layer between the first electrode **210** and the light emitting layer, and an electron injection layer and/or an electron transport layer between the second electrode **240** and the light emitting layer.

The second electrode **240** disposed on the light-emissive organic layer **230** may be a cathode electrode and formed of metal having a low work function such as Al, Mg, Ca, Ag or their alloy.

The OLED apparatus according to an embodiment of the present invention may be a rear light-emissive type where light emitted from the light-emissive organic layer **230** passes through the TFT substrate **100** or a front light-emissive type where light emitted from the light-emissive organic layer **230** passes through the front module **700**.

In case of the rear light-emissive type OLED apparatus, the second electrode **240** may have a thickness enough to reflect light.

On the other hand, in case of the front light-emissive type OLED apparatus, the second electrode **240** may have a thickness thin enough (e.g., 1 Å to 50 Å) to transmit light, and a reflecting layer (not shown) formed of Al, Ag or Ni may be

arranged below the first electrode **210**. Also, as illustrated in FIG. 4, the capping layer **250** may be formed on the second electrode **240**. The capping layer **250** is used to reduce or prevent the light emitted from the light-emissive organic layer **230** from being totally reflected above the second electrode **240**, and may be formed of a mixture of a conductive inorganic material and an organic material. A metal, for example, transition metal, alkali metal, alkali earth metal, rare-earth metal, or their alloy of two or more metals may be used as the conductive inorganic material. An organic material (for example, material that may be used as a host material of the hole transport layer) having excellent hole mobility or an organic material (for example, material that may be used as a host material of the electron transport layer) having excellent electron mobility may be used as the organic material. The conductive inorganic material may increase scattering of light and absorption of light by generating surface Plasmon resonance at the capping layer **250**, and may prevent total reflection from occurring above the second electrode **240**, whereby light extraction effect of the OLED apparatus is improved.

Meanwhile, as illustrated in FIG. 4, the OLED apparatus according to an embodiment of the present invention includes a passivation layer **300** formed on the TFT substrate **100** to cover the organic light emitting element **200**.

The passivation layer **300** includes a first inorganic layer **310** formed on the TFT substrate **100** and the organic light emitting element **200**, an organic layer **320** on the first inorganic layer **310**, and a second inorganic layer **330** on the organic layer **320**.

The first and second inorganic layers **310** and **330** may be formed of a material that includes one or more of Al<sub>2</sub>O<sub>3</sub>, SiO<sub>2</sub>, Si<sub>3</sub>N<sub>4</sub>, SiON, AlON, AlN, TiO<sub>2</sub>, ZrO, ZnO, and Ta<sub>2</sub>O<sub>5</sub>, and the organic layer **320** may be formed of an organic matter suitable for shielding water/oxygen, such as acrylic resin, epoxy resin, polyimide resin, and polyethylene. The organic layer **320** serves to reduce stress between the respective layers, which occurs when the OLED apparatus is bent.

The OLED apparatus further includes a viscoelastic layer **400** formed on the TFT substrate **100** to fully cover the passivation layer **300**, and an encapsulation film **500** on the viscoelastic layer **400**.

Hereinafter, the viscoelastic layer **400** according to an embodiment of the present invention will be described in more detail with reference to FIGS. 7 and 8.

FIG. 7 is a Maxwell model of a viscoelastic material, and FIG. 8 is a graph illustrating variation of stress with time of a viscoelastic material measured through a relaxation modulus test.

The viscoelastic layer **400** is formed of a viscoelastic material that may be displayed as a Maxwell model illustrated in FIG. 5. As illustrated in FIG. 5, the viscoelastic material generally includes a dashpot element  $\eta$  and a spring element E.

As illustrated in the graph of FIG. 8, if a rapid strain is given to the viscoelastic material at a predetermined temperature through the relaxation modulus test, the spring element E is immediately stretched and at the same time stress  $\sigma$  is generated. However, as time T passes, a strain of the spring element E is offset by the dashpot element  $\eta$ , and stress  $\sigma$  is rapidly reduced and then is converged to a specific value.

The relaxation modulus test is a linear viscoelastic measurement method, which is performed to obtain information on a structure of a material having viscoelasticity. The relaxation modulus test measures variation of stress with the lapse of time when a constant strain is given at a predetermined temperature condition. Namely, stress caused by a stimulus

such as a strain, which is given to the material, is measured by a reaction of the material to the stimulus.

Preferably, the viscoelastic layer **400** is formed of a viscoelastic material that basically satisfies characteristics, such as water vapor transmissibility of about 10 g/m<sup>2</sup>/day or less, visible light transmissibility of about 95% or more and a modulus of about 0.3 MPa or less, at the same time. The viscoelastic layer **400** is used to encapsulate the OLED apparatus.

In addition, the viscoelastic layer **400** is formed of a viscoelastic material, and its elastic portion ( $E_p$ ), which is defined by the following Equation 1, is about 30% or more:

$$\text{Elastic portion}(E_p)(\%)=(\sigma/\sigma_0)\times 100, \quad \text{<Equation 1>}$$

wherein  $\sigma_0$  is initial stress generated when a strain of about 50% is applied to the viscoelastic material and  $\sigma$  is final stress measured after the strain is continuously applied thereto for about 180 seconds, with the initial stress  $\sigma_0$  and the final stress  $\sigma$  being measured at about 80° C. through a relaxation modulus test.

In other words, the elastic portion  $E_p$  may be used as a reference for determining whether a certain viscoelastic material is suitable for the encapsulation structure of the OLED apparatus. When the viscoelastic layer **400** has an elastic portion  $E_p$  of about 30% or more, bubbles that might be recognized under an environment of high temperature and high humidity may remarkably be reduced or prevented from occurring.

The viscoelastic layer **400** may be formed of a viscoelastic material that includes acryl resin, olefin resin, synthetic rubber, or mixture of two or more thereof.

The encapsulation film **500** formed on the viscoelastic layer **400** may include an optically-isotropic film **540**, a first organic film **530** on the optically-isotropic film **540**, an inorganic film **520** on the first organic film **530**, and a second organic film **510** on the inorganic film **520**. The second organic film **510** may be directly in contact with the viscoelastic layer **400**.

The inorganic film **520** may be formed of a material that includes one or more of Al<sub>2</sub>O<sub>3</sub>, SiO<sub>2</sub>, Si<sub>3</sub>N<sub>4</sub>, SiON, AlON, AlN, TiO<sub>2</sub>, ZrO, ZnO, and Ta<sub>2</sub>O<sub>5</sub>, and the first and second organic films **510** and **530** may be formed of an organic matter suitable for shielding water/oxygen, such as acryl resin, epoxy resin, polyimide resin, and polyethylene. The first and second organic films **510** and **530** serve to reduce stress which occurs when the OLED apparatus is bent.

According to one embodiment of the present invention, the viscoelastic layer **400** and the encapsulation film **500** have a water vapor transmission rate of about 5×10<sup>-2</sup> g/m<sup>2</sup>/day or less. In order to have the water vapor transmission rate, the encapsulation film **500** may further include additional inorganic film and/or additional organic film.

As illustrated in FIG. 4, the OLED apparatus according to one embodiment of the present invention further includes a circular polarizing plate **600** on the encapsulation film **500**, and a front module **700** on the circular polarizing plate **600**.

For adhesion with the circular polarizing plate **600**, the encapsulation film **500** may further include an adhesive film on the optically-isotropic film **540**.

Also, for adhesion between the circular polarizing plate **600** and the front module **700**, the OLED apparatus may further include an adhesive layer (not shown) formed of an adhesive material such as a pressure sensitive adhesive (PSA) and an optically clear adhesive (OCA).

The circular polarizing plate **600** is used to reduce or prevent visibility deterioration from occurring, which is caused as the external light reflected by the organic light emitting

element **200** is emitted from the OLED apparatus, and may reduce or prevent the external light reflected by the second electrode **240** of the organic light emitting element **200** from being emitted from the OLED apparatus.

The circular polarizing plate **600** may include a  $\lambda/4$  phase difference film **610** on the encapsulation film **500** and a linear polarizing film **620** on the  $\lambda/4$  phase difference film **610**. The external light becomes the linear polarizing light after passing through the linear polarizing film **620**. The linear polarizing light passes through the  $\lambda/4$  phase difference film **610**, is reflected by the second electrode **240** and converted to a linear polarizing light vertical to a transmission axis of the linear polarizing film **620** after passing through again the  $\lambda/4$  phase difference film **610**, and then is absorbed by the linear polarizing film **620**.

The  $\lambda/4$  phase difference film **610** may have a thickness of about 50 nm to about 100 nm and a phase retardation value of about 120 nm to about 148 nm.

In order to effectively reduce or prevent the external light reflected by the second electrode **240** of the organic light emitting element **200** from being visible by being emitted from the OLED apparatus, the optically-isotropic film **540** of the encapsulation film **500** may be an isotropic film having a phase retardation value of about 10 nm or less.

The front module **700** may include a touch film **710** and a cover window **720**, and may be attached to the circular polarizing plate **500** using an adhesive layer. The cover window may be formed of glass or plastic.

Hereinafter, a method for manufacturing an OLED apparatus according to an embodiment of the present invention will be described in detail with reference to FIGS. 9 to 15.

First of all, as illustrated in FIG. 9, after a substrate **100a** that includes a thin film transistor **130** is prepared, an organic light emitting element **200** is formed on the substrate **100a**.

In order to prepare the substrate **100a**, a polyimide film **110** is formed on a glass substrate **101**. Subsequently, a buffer layer **120** of an inorganic material is formed on the polyimide film **110**.

The semiconductor layer **131** and the capacitor lower electrode **141** are formed to be spaced apart from each other on the buffer layer **120**. The semiconductor layer **131** may be amorphous silicon, polysilicon, or oxide semiconductor.

A gate insulating film **150** is formed on the buffer layer **120** provided with the semiconductor layer **131** and the capacitor lower electrode **141**. The gate insulating film **150** may be formed of a silicon oxide film (SiOx) or a silicon nitride film (SiNx).

The gate electrode **132** and the capacitor upper electrode **142** are respectively formed on the gate insulating film **150** to be respectively overlapped with the semiconductor layer **131** and the capacitor lower electrode **141**. The gate electrode **132** and the capacitor upper electrode **142** may be formed of Al, Mo, Cr, Au, Ti, Ni, Cu, or their alloy of two or more.

Subsequently, an interlayer insulating film **160** is formed on the gate insulating film **150** provided with the gate electrode **132** and the capacitor upper electrode **142**. The interlayer insulating film **160** may be an inorganic single film or an inorganic/organic double film.

The interlayer insulating film **160** and the gate insulating film **150** may selectively be etched at both sides of the gate electrode **132** interposed between the interlayer insulating film **160** and the gate insulating film **150**, whereby two via holes partially exposing the semiconductor layer **131** are formed. Subsequently, after a metal layer is formed of Al, Mo, Cr, Au, Ti, Ni, Cu or their alloy of two or more on the

interlayer insulating film **160**, source and drain electrodes **133** and **134** are formed by photolithography and etching processes.

An overcoat layer **170** for passivating the thin film transistor **130** and the capacitor **140** and planarizing the step difference caused by the thin film transistor **130** is formed on the interlayer insulating film **160** provided with the source and drain electrodes **133** and **134**. The overcoat layer **170** may be an inorganic single layer or an inorganic/organic double layer.

In order to form the organic light emitting element **200** on the substrate **100a** completed as above, the overcoat layer **170** is selectively etched, whereby a hole for partially exposing the drain electrode **134** is formed. Subsequently, after a transparent conductive material having a high work function, such as ITO, IZO, ITZO, ICO, or ZnO, is deposited on the substrate **100a** through a CVD or sputtering process, the first electrode **210** is formed by photolithography and etching processes.

In the case that the front light-emissive type OLED apparatus is manufactured, a reflective layer (not shown) may be formed on the substrate **100a** before forming the first electrode **210** with metal such as Ag or Ni.

After an organic insulating layer is formed on the substrate **100a** provided with the first electrode **210** by using an organic non-conductive material such as benzocyclobutene (BCB), acryl resin, epoxy resin, polyamide resin, and polyimide resin, a selective etching process is performed to etch the organic insulating layer to form a bank layer **220** having a bank hole, which exposes at least a part of the first electrode **210**.

Subsequently, a light-emissive organic layer **230**, a second electrode **240**, and a capping layer **220** are sequentially formed on the bank layer **220** and the first electrode **210** by the known methods.

The second electrode **240** disposed on the light-emissive organic layer **230** may be formed of Al, Mg, Ca, Ag or their alloy, which has a low work function. In the case that the rear light-emissive type OLED apparatus is manufactured, the second electrode **240** is formed to have a thickness thick enough to reflect light. On the other hand, in the case that the front light-emissive type OLED apparatus is manufactured, the second electrode **240** is formed to have a thickness thin enough (e.g., 1 Å to 50 Å) to transmit light.

The capping layer **250**, which is used to reduce or prevent the light emitted from the light-emissive organic layer **230** from being totally reflected above the second electrode **240**, is formed on the second electrode **240**. The capping layer **250** may have a thickness of about 10 nm to about 100 nm.

As described above, the capping layer **250** may be formed of a mixture of a conductive inorganic material and an organic material. A metal, for example, transition metal, alkali metal, alkali earth metal, rare-earth metal, or their alloy of two or more metals may be used as the conductive inorganic material. For example, if a nanosilver particle is used as the conductive inorganic material, the nanosilver particle and the organic material are respectively jetted and then deposited on the second electrode **240** to form the capping layer **250**, wherein the content of the nanosilver particle contained in the capping layer **250** may be less than about 10% by weight.

Subsequently, as illustrated in FIG. 10, the passivation layer **300** is formed on the substrate **100a** to fully cover the organic light emitting element **200**.

The step of forming the passivation layer **300** includes the steps of forming the first inorganic layer **310** on the TFT substrate **100** and the organic light emitting element **200**, forming the organic layer **320** on the first inorganic layer **310**, and forming the second inorganic layer **330** on the organic layer **320**.

Each of the first and second inorganic layers **310** and **330** may be formed of a material that includes one or more of Al<sub>2</sub>O<sub>3</sub>, SiO<sub>2</sub>, Si<sub>3</sub>N<sub>4</sub>, SiON, AlON, AlN, TiO<sub>2</sub>, ZrO, ZnO, and Ta<sub>2</sub>O<sub>5</sub>, and the organic layer **320** may be formed of an organic matter suitable for shielding water/oxygen, such as acryl resin, epoxy resin, polyimide resin, and polyethylene.

Since the light-emissive organic layer **230** may be damaged at a high temperature of 110 or more, it is preferable that the first and second inorganic layers **310** and **330** are formed through a low temperature PECVD or ALD process of 80 to 100.

The organic layer **320** may be formed through vapor deposition, coating or printing.

Subsequently, as illustrated in FIG. 11, the encapsulation film **500** is attached onto the passivation layer **300** through the viscoelastic layer **400**. The viscoelastic layer **400** may be a double sided tape.

The viscoelastic layer **400** according to an embodiment of the present invention, which is interposed between the passivation layer **300** and the encapsulation film **500**, is formed of a viscoelastic material, and its elastic portion, which is defined by Equation 1, is about 30% or more.

$$\text{Elastic portion(\%)} = (\sigma/\sigma_0) \times 100, \quad \text{<Equation 1>:}$$

$\sigma_0$  is initial stress generated when a strain of about 50% is applied to the viscoelastic material and  $\sigma$  is final stress measured after the strain is continuously applied thereto for about 180 seconds. The initial stress  $\sigma_0$  and the final stress  $\sigma$  are measured at about 80° C. through a relaxation modulus test.

As described above, the viscoelastic material may include acrylic resin, olefin resin, synthetic rubber or mixture of two or more thereof, which satisfies various characteristics of the encapsulation structure of the OLED apparatus, that is, water vapor transmissibility of about 10 g/m<sup>2</sup>/day or less, visible light transmissibility of about 95% or more, and modulus of about 0.3 MPa or less.

According to one embodiment of the present invention, the first organic film **530**, the inorganic film **520**, and the second organic film **510** are sequentially deposited on the optically-isotropic film **540**, whereby the encapsulation film **500** which is separately formed may be attached to the passivation layer **300** and the TFT substrate **100** through the viscoelastic layer **400**. At this time, the second organic film **510** is directly in contact with the viscoelastic layer **400**.

The first and second organic films **510** and **530** may be formed by vapor deposition, coating or printing of an organic matter suitable for shielding water/oxygen, such as acryl resin, epoxy resin, polyimide resin, and polyethylene.

The inorganic film **520** may be formed through a CVD or ALD process, and include an inorganic matter such as Al<sub>2</sub>O<sub>3</sub>, SiO<sub>2</sub>, Si<sub>3</sub>N<sub>4</sub>, SiON, AlON, AlN, TiO<sub>2</sub>, ZrO, ZnO, and Ta<sub>2</sub>O<sub>5</sub>, for example.

After adhesion of the encapsulation film **500**, as illustrated in FIG. 12, the circular polarizing plate **600**, which is separately formed, is attached onto the encapsulation film **500**. For adhesion with the circular polarizing plate **600**, the encapsulation film **500** may further include an adhesive film on the optically-isotropic film **540**.

The circular polarizing plate **600** may include a  $\lambda/4$  phase difference film **610** attached onto the encapsulation film **500** and a linear polarizing film **620** on the  $\lambda/4$  phase difference film **610**.

Subsequently, as illustrated in FIG. 13, the front module **700** that includes a touch film **710** and a cover window **720** is attached onto the circular polarizing plate **600**. For adhesion between the circular polarizing plate **600** and the front mod-

ule 700, an adhesive such as a pressure sensitive adhesive (PSA) and an optically clear adhesive (OCA) may be used.

Subsequently, as illustrated in FIG. 14, the glass substrate 101 which has performed a support function during the manufacturing process may be separated from the polyimide film 110 using a laser. For ease of separation, a sacrificing layer (not shown), which can be heated and decomposed by absorbing an irradiated laser, may further be formed between the glass substrate 101 and the polyimide film 110.

Subsequently, as illustrated in FIG. 15, after the glass substrate 101 is separated from the polyimide film 110, a rear plate 190 may be attached to the polyimide film 110 using an adhesive layer 180 such as a pressure sensitive adhesive (PSA) and an optically clear adhesive (OCA) as a support for the OLED apparatus according to an embodiment of the present invention.

Hereinafter, experiment results according to embodiments of the present invention will be described, along with a comparison example, in more detail.

EXPERIMENTS

Measurement of Elastic Portion ( $E_p$ ) (%) of Viscoelastic Material

A relaxation modulus test was carried out by means of the rheometer of ARES (currently, TA Instrument) for viscoelastic materials of a double-sided tape type used to manufacture an encapsulation structure of an OLED apparatus, under the following conditions.

Mode: stress relaxation mode

Strain: 50%

Temperature: 80° C.

Duration: 180 seconds

Axial force/strain: set to 'disabled'

Through the relaxation modulus tests, the initial stress  $\sigma_0$  generated when a strain of 50% is applied to the viscoelastic material and the final stress  $\sigma$  after the strain is maintained for 180 seconds were respectively measured, and then the elastic portions ( $E_p$ ) (%) of the viscoelastic materials were obtained in accordance with the following Equation 1:

$$\text{Elastic portion}(E_p)(\%)=(\sigma/\sigma_0)\times 100. \quad \text{<Equation 1>}$$

Examples 1 to 3

Organic light emitting display apparatuses having the structure of FIG. 4 were manufactured using viscoelastic materials having elastic portions ( $E_p$ ) of 30%, 35% and 40% respectively.

Comparative Example

An organic light emitting display apparatus having the structure of FIG. 4 was manufactured using a viscoelastic material having an elastic portion ( $E_p$ ) of 20%.

A reliability test was performed in accordance with the following method for the OLED apparatuses of the examples 1 to 3 and comparative example, and the results thereof are shown in the following Table 1.

Reliability Test

10 samples per each apparatus were provided at the high temperature of 80° C. for 180 hours, and then a visual inspection was performed to see whether visually recognizable bubbles had been generated.

TABLE 1

	Elastic portion ( $E_p$ ) of viscoelastic material (%)	The number of samples where bubble(s) was(were) observed	Remark
Ex. 1	30	0	—
Ex. 2	35	0	—
Ex. 3	40	0	—
Comp. Ex.	20	4	A total of seven bubbles occurred at four samples

As shown in Table 1, visually recognizable bubbles, which otherwise might be generated under an environment of high temperature and high humidity, are remarkably reduced or prevented when the encapsulation structure is manufactured using the viscoelastic material having an elastic portion ( $E_p$ ) of 30% or more.

As described above, visually recognizable bubbles can be remarkably reduced or prevented within an encapsulation structure of an OLED apparatus even under an environment of high temperature and high humidity.

Accordingly, not only can the productivity of the OLED apparatus be improved, but also the deterioration of the product reliability and damage to the brand image due to the visually recognizable bubbles can be reduced or prevented.

Also, a reference for determining whether a certain viscoelastic material is suitable for an encapsulation structure of an OLED apparatus may be provided.

It will be apparent to those skilled in the art that various modifications and variation can be made in the present invention without departing from the spirit or scope of the invention. Thus, it is intended that the present invention cover the modifications and variations of this invention provided they come within the scope of the appended claims and their equivalents.

What is claimed is:

1. An organic light emitting display (OLED) apparatus, comprising: a substrate; an organic light emitting element on the substrate, the organic light emitting element including a first electrode, an organic light emitting layer and a second electrode; a viscoelastic layer on the organic light emitting element, wherein an elastic portion of the viscoelastic layer is about 30% or more, the elastic portion being defined by Equation 1:

$$\text{Elastic portion}(E_p)(\%)=(\sigma/\sigma_0)\times 100, \quad \text{<Equation 1>}$$

wherein  $\sigma_0$  is an initial stress generated when a strain of about 50% is applied to the viscoelastic layer and  $\sigma$  is a final stress measured after the strain is continuously applied thereto for about 180 seconds, with the initial stress  $\sigma_0$  and the final stress  $\sigma$  being measured at about 80° C. through a relaxation modulus test.

2. The OLED apparatus according to claim 1, further comprising a passivation layer between the organic light emitting element and the viscoelastic layer, wherein the passivation layer has a combination of an organic layer and an inorganic layer.

3. The OLED apparatus according to claim 1, wherein the viscoelastic layer satisfies at least one of a water vapor transmissibility of about 10 g/m<sup>2</sup>/day or less, a visible light transmissibility of about 95% or more, and a modulus of about 0.3 MPa or less.

4. The OLED apparatus according to claim 1, wherein the viscoelastic layer includes at least one of acryl resin, olefin resin and synthetic rubber.

5. The OLED apparatus according to claim 1, further comprising an encapsulation film on the viscoelastic layer. 5

6. The OLED apparatus according to claim 5, wherein the encapsulation film has a combination of an organic layer and an inorganic layer.

7. The OLED apparatus according to claim 6, wherein the organic layer of the encapsulation film is in contact with the viscoelastic layer. 10

8. The OLED apparatus according to claim 6, wherein the organic layer of the encapsulation film includes at least one of acryl resin, epoxy resin, polyimide resin and polyethylene.

9. The OLED apparatus according to claim 6, wherein the inorganic layer of the encapsulation film includes at least one of  $Al_2O_3$ ,  $SiO_2$ ,  $Si_3N_4$ ,  $SiON$ ,  $AlON$ ,  $AlN$ ,  $TiO_2$ ,  $ZrO$ ,  $ZnO$  and  $Ta_2O_5$ . 15

10. The OLED apparatus according to claim 5, further comprising a circular polarizing plate on the encapsulation film, and a touch film on the polarizing plate. 20

\* \* \* \* \*

专利名称(译)	包括粘弹性层的有机发光显示装置及其制造方法		
公开(公告)号	<a href="#">US9203051</a>	公开(公告)日	2015-12-01
申请号	US14/535471	申请日	2014-11-07
[标]申请(专利权)人(译)	乐金显示有限公司		
申请(专利权)人(译)	LG DISPLAY CO. , LTD.		
当前申请(专利权)人(译)	LG DISPLAY CO. , LTD.		
[标]发明人	BYUN HYUN TAE SONG EUN AH LIM HEE CHUL		
发明人	BYUN, HYUN TAE SONG, EUN AH LIM, HEE CHUL		
IPC分类号	H01L51/00 H01L51/52 H01L27/32		
CPC分类号	H01L51/5253 H01L27/323 H01L2251/5338 H01L51/5262 H01L51/5281 H01L51/5256		
代理机构(译)	DENTONS美国律师事务所		
审查员(译)	阮DUYỄ		
优先权	1020130145331 2013-11-27 KR		
其他公开文献	US20150144909A1		
外部链接	<a href="#">Espacenet</a> <a href="#">USPTO</a>		

摘要(译)

公开了一种有机发光显示 ( OLED ) 装置, 其包括基板; 基板上的有机发光元件, 所述有机发光元件包括第一电极, 有机发光层和第二电极; 有机发光元件上的粘弹性层, 其中粘弹性层的弹性部分为约30%或更多, 弹性部分由 & # x3c; 定义: 等式1> : 弹性部分 ( E p ) ( % ) = ( σ / σ 0 ) × 100 , 其中 σ 0 是当约50%的应变施加到粘弹性层时产生的初始应力 σ 是在连续施加应变约180秒后测量的最终应力, 初始应力 σ 0 , 最终应力 σ 通过松弛模量试验在约80°C下测量。

